

CDE HAM III

SERIES 2 ROTOR SYSTEM

OWNER'S MANUAL

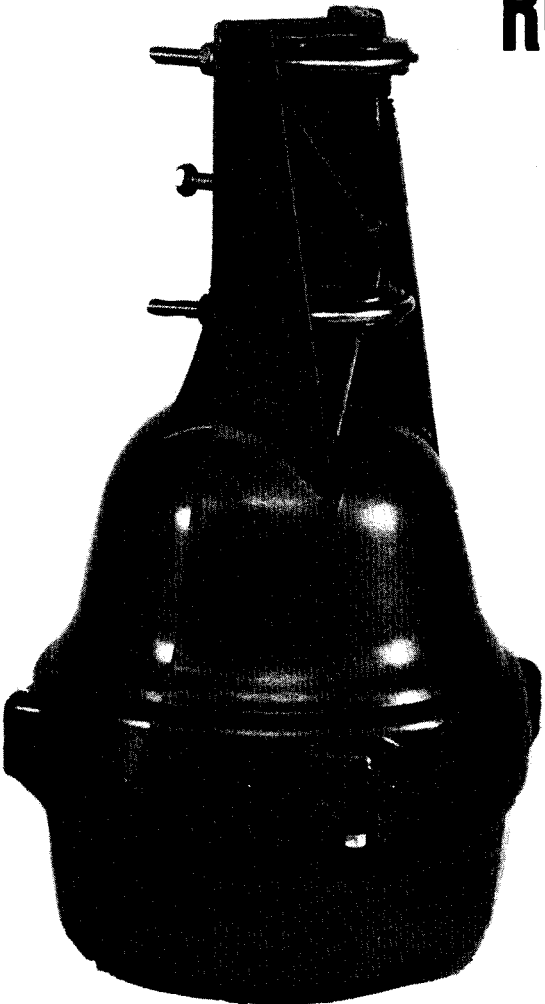

5-520

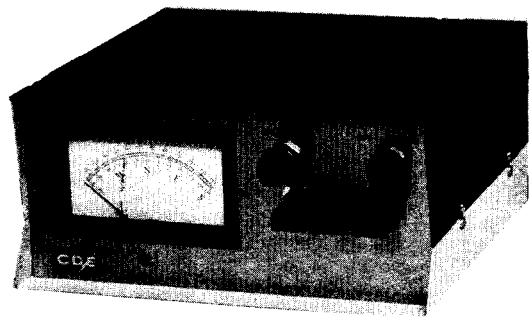

THE HAM III IS RECOMMENDED FOR ANTENNA ARRAYS NO LARGER THAN 12.5 SQUARE FEET OF WIND SURFACE AREA WHEN TOWER MOUNTED AND 7.5 SQUARE FEET OF ANTENNA WIND SURFACE AREA WHEN MAST MOUNTED USING THE LOWER MAST SUPPORT. FOR LARGER ANTENNAS, THE T²X HEAVY DUTY ROTOR IS RECOMMENDED.



CORNELL-DUBILIER ELECTRONICS

DIVISION OF FEDERAL PACIFIC ELECTRIC COMPANY

Rotor Department

Fuquay-Varina, North Carolina 27526

HAM III SERIES 2

INSTALLATION AND OPERATION

I. CAUTIONS - READ CAREFULLY

- A. Install **PROPERLY AND SAFELY**.
- B. Towers, often the highest **METAL** parts in the vicinity, **REQUIRE EXTREME CAUTION** during erection and placement. **EXTREME CARE** must be taken during erection so that **METAL TOWERS AND BEAMS DO NOT CONTACT POWER LINES** even if the beams slip or rotate, towers fall or fracture, or metal wires blow in the wind, etc.
- C. Metal towers or other position mechanisms **MUST BE PLACED SO THAT IF THEY FRACTURE OR BLOW OVER** in high winds, **THEY CANNOT CONTACT POWER LINES**, be a hazard to individuals, or endanger property.
- D. When not mounted within a tower with a thrust bearing as shown in Figure 1, the rotator must be **DERATED**.
- E. Metal towers must be **GROUNDING PROPERLY** at the **TOWER LOCATION BEFORE THE TOWER IS ERECTED**. This is to minimize electrical hazard and the possibility of lightning damage. Do not bury bare aluminum wires or stakes in the ground. Use copper ground stakes. The service entrance ground should be checked. The household 120 VAC convenience outlet should be the 3-prong type (grounded back to the service entrance).
- F. The **CONTROL BOX** is not weather-proof and must be located in the house, ham shack or other **PROTECTED LOCATION**.

G. Read this manual fully **BEFORE PROCEEDING**.

The HAM III rotor has been carefully designed and manufactured to give many years of trouble-free service when carefully and professionally installed. It consists of the strongest and best commercially available components. The design is based upon many years of experience by the Bell Rotor People - Cornell-Dubilier Electronics in North Carolina.

II. COMPONENTS OF THE HAM III

The HAM III (Series 2) rotor consists of a bell type rotator, a metered control unit, and the necessary mounting hardware. The stock HAM III is intended for in-tower mounting on the base plate which is part of the tower. However, in some instances, mast mounting is desired. The lower mast support kit, P/N 51467-10, contains a lower mast support and the necessary hardware to facilitate mounting the HAM III ROTATOR on top of a mast: **CAUTION: When using the lower mast support, antenna size is restricted to 7.5 square feet of wind surface area.** The rotator unit must be wired to the control unit with an 8-wire cable. The control unit must be placed inside the house or other protected location. Included in the rotor are:

- A. Owners manual P/N 51418-10
- B. Rotator P/N 51451-10
- C. Mounting Hardware Kit P/N 51415-10
- D. Control unit P/N 51435-10

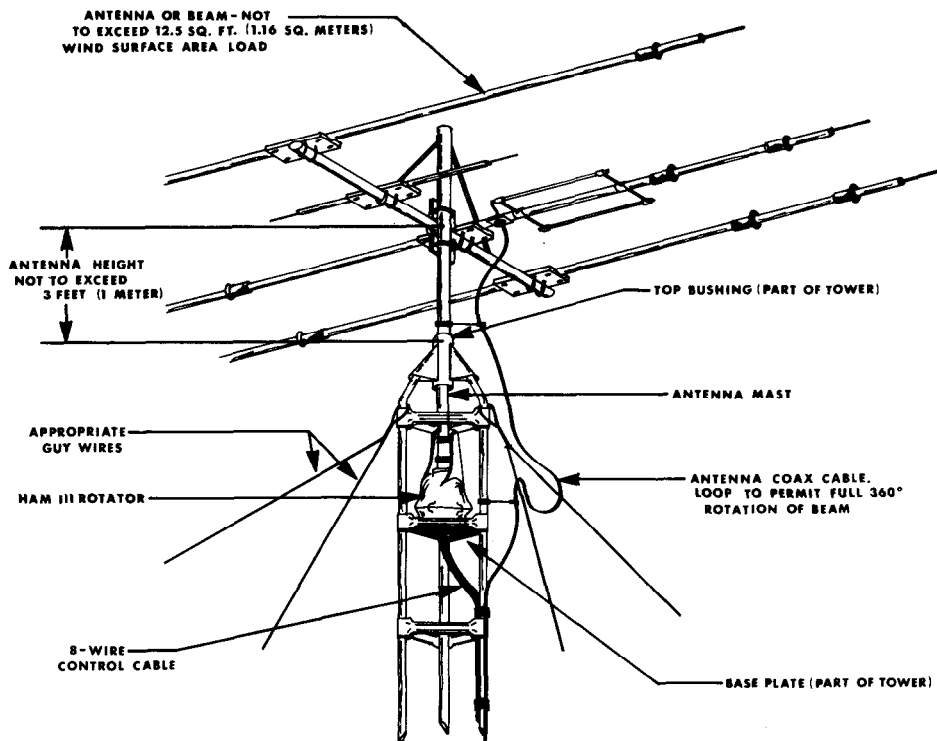

FIG. 1 - INSIDE TOWER MOUNTING

Each installation has different requirements. There are a wide variety of towers available. The gauge of the 8-wire cable to connect the control unit to the rotator **DEPENDS UPON THE DISTANCE BETWEEN THE ROTATOR AND CONTROL**. The longer the distance the larger the diameter of the wire required. Various antennas or beams require different installation methods. For this reason, the owner must procure the remainder of the components after checking their compatibility. In general, these will be:

- A. The beam or antenna desired and a suitable antenna mast.
- B. A tower or other mechanism to position the rotator and beam for safe and effective rotation (see **CAUTIONS**).
- C. 8-wire cable to connect the control to the rotator. (See specificatoin).
- D. Coaxial cable to connect the beam to the communications equipment.
- E. Appropriate guy wires as required.
- F. Grounding hardware.
- G. Optional lower heavy duty Mast Support Kit must be procured if the owner elects to use an "outside" tower mount (see figures 2 and 3). The part number for the Lower Mast Support Kit is 51467-10. "Inside" tower (figure 1) is recommended.

III. INSTALLATION INFORMATION

A. TYPES OF INSTALLATIONS

There are three general types of installations (see figures 1 through 3).

1. **THE RECOMMENDED INSTALLATION** is an "inside" tower mount with a top bushing or bearing to provide support and resist high wind loads.

When the rotator is properly mounted this way, it can be rated to turn an antenna or beam of 12.5 square feet wind surface area. The wind loading during storms, the rotational inertia of the beam, and unbalanced weight are more important than the dead weight of the beam. It is important to minimize the height of the beam above the rotator to minimize the overturning force induced in a high wind (see "Unbalanced Weight" and "Wind Pressure").

2. An "outside" tower mount as shown (See Figure 2) is optional. The rotator is not as well protected but the installation is simpler. The owner must procure the Heavy Duty Lower Mast Support Kit, P/N 51467-10, to install as in figure 2 and derate to 7.5 square feet.
3. A telescoping or other-type mast as shown, see figure 3, can also be used. This installation is similar to #2 above and requires the optional Heavy Duty Lower Mast Support Kit and must be derated to 7.5 square feet.

There are variations of the above falling generally into one of the above categories. For example, the rotator may be mounted lower in the tower than shown in Figure 1. In that case, more than one bushing or thrust bearing for the beam mast may be required and longer coast down time allowed in operation. These factors are interrelated and the components must be matched together.

B. UNBALANCED WEIGHT AND WIND PRESSURE

1. **UNBALANCED WEIGHT:** Weight should be as closely balanced as possible. Unbalanced weight creates a bending moment of force which is concentrated on the mast at the

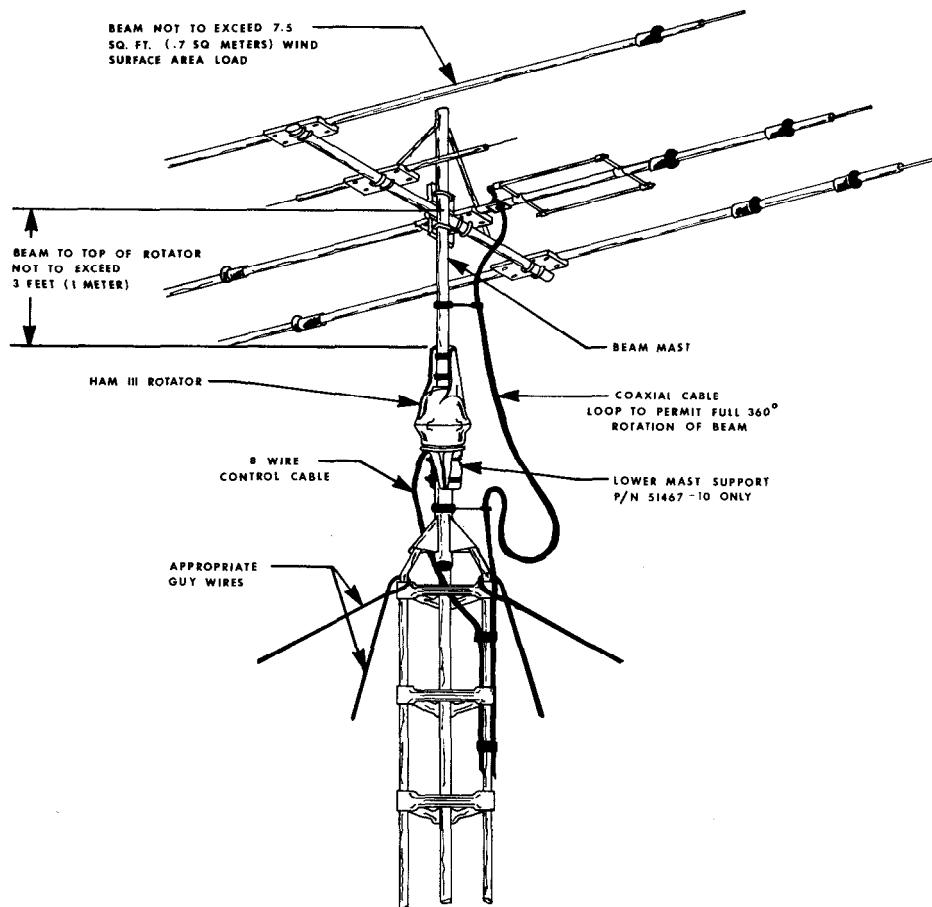

FIG. 2 - TOP OF TOWER MOUNTING

point where it is clamped to the top of the rotor. This moment tends to strain the mast at that point and also to bind the ball bearings by creating excessive downward pressure on one side and upward pressure on the other. Such unbalance places additional stress on the motor and gear train. Unbalanced weight becomes critical as the distance from the antenna boom to the clamping point at the rotor is increased.

2. **WIND PRESSURE** against the boom and elements produces a bending force on the mast which can cause the same stresses as unbalanced weight. To strengthen the installation to withstand unbalanced weight and wind pressure the top mast should be as short and as strong as possible. In multiple arrays the heaviest sections should be closest to the rotator. In order to distribute the bending stress and prevent fracture of the mast, the HAM III rotor includes a specially designed steel clamping plate to clamp the mast to the rotator. After procuring the type of tower or other positioning mechanism of the owner's choice, the next step is to wire the rotator to the control box and check out its operation prior to installation.

IV. WIRING AND CHECK - OUT

A preliminary operation check should be made prior to installation. We recommend the following procedure:

- A. Decide the wire gauge (size) required and procure the number of feet of the proper cable-see table, on page 11.
- B. Strip and tin $\frac{3}{8}$ " on both ends (16 wires) after removing about 4 inches of the jacket. Tinning can be accomplished.

after twisting the strands together, with an ordinary soldering iron and radio solder being careful not to melt the insulation.

- C. With the control unit and the rotator on the work table, connect the cable between the rotator and control unit using the full length of cable that will be used in the installation. **IT IS IMPORTANT THAT #1 TERMINAL ON THE ROTATOR IS CONNECTED TO THE #1 TERMINAL ON THE CONTROL UNIT AND SO ON. NOTE:** The specifications call for **HEAVIER** gauge wire in two locations. **LEADS #1 and #2 must be HEAVIER GAUGE and less total lead resistance** (See specifications Page 11). Wire the control to the rotator as shown in figures 4 and 5.

CAUTION - - SHORTS BETWEEN TERMINALS OR GROUND-ED LEADS MAY DAMAGE THE ROTOR.

- D. With the rotator sitting in the upright position and connected to the control unit, by the eight (8) wire cable, plug the control unit power cord into a 120 VAC 50/60 Hz wall receptacle.
- E. Turn the power switch on. The meter should be illuminated.
- F. Depress the "Brake Release" (center) lever, then release it. An audible click should be heard in the rotator. This is the solenoid operating the brake wedge.
- G. Depress the "Brake Release" (Center) lever, hold it, and simultaneously depress the CW direction switch (Right). The rotator should turn CW (looking from the top). This is S - W - N - E - S. Release the CW direction switch; the rotator will coast down and stop. Now release the brake switch. The rotator is now locked into position.

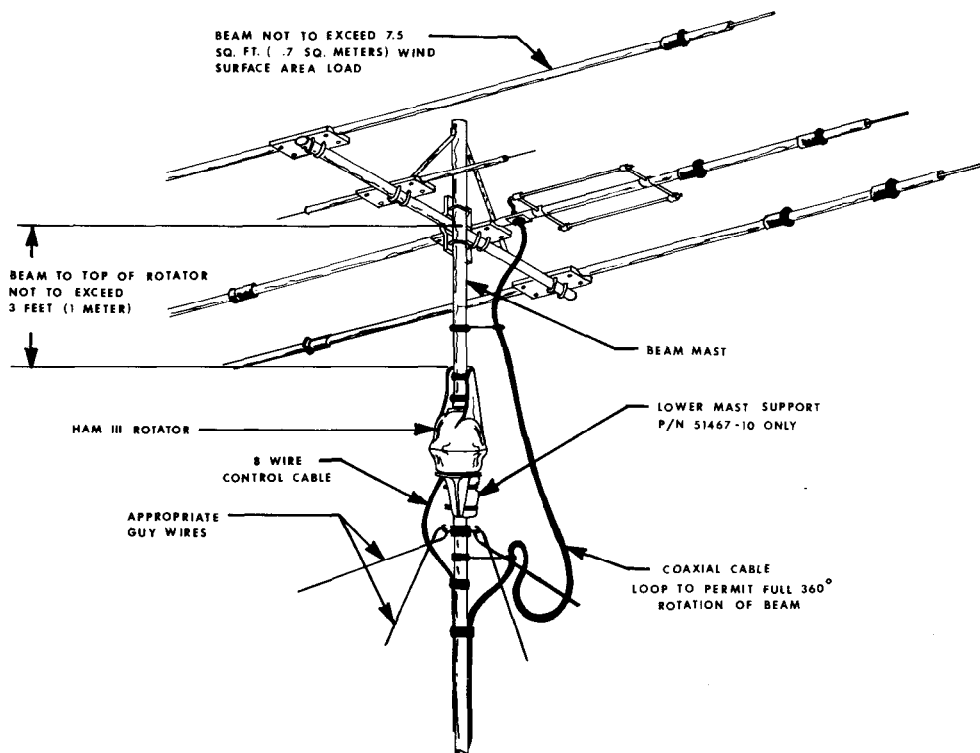

FIG. 3 - POLE MOUNTING

- H. Repeat the above for CCW direction by depressing the brake switch first, then the CCW direction switch (left).

CAUTION: It is best to release the direction switch just prior to the end of rotation (extreme CW or CCW position) in order not to cause undue stress on the stop arm and/or the gears.

- I. Return the rotator to full CCW position.

V. MOUNTING THE ROTATOR

- A. **INSIDE TOWER** The rotator is mounted inside a tower (see figure 1) to the flat tower plate by means of four bolts furnished in the hardware kit. Use the following procedure:

1. Locate the rotator in the tower directly under the bushing. Note that the tower plate must be cut out to allow the connecting 8 wire cable to pass through the plate.
2. The rotator is attached to the tower plate by means of 4 bolts and lockwashers (see figure 6). The flat tower plate must be drilled in four places using the template provided with this manual unless the tower plate is already properly drilled.
3. Tighten the 4 bolts but not to final tightness. Observe how the rotator turns. It must rotate in such a manner as to turn the mast concentrically to the top bushing.
4. Trial assemble the mast to the top of the rotator using the U-bolts, nuts, and lock washers through the rotator and clamp plate as shown in Figure 6. The maximum mast diameter that may be used is 2 1/16" O. D. We recommend 1 1/2" nominal **STEEL PIPE** with 1.9" O. D. in standard wall thickness of .145". For stacked arrays or very large beams, we recommend extra heavy duty wall thickness .200". Both steel pipes can be purchased to specification ASTM-120.

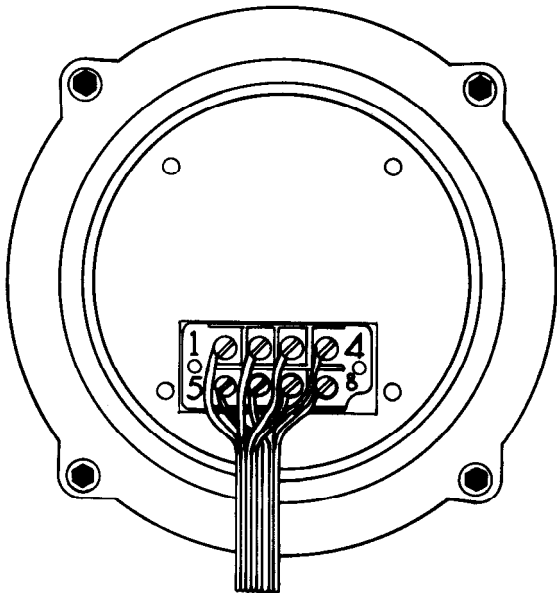

FIG. 4: ROTATOR WIRING

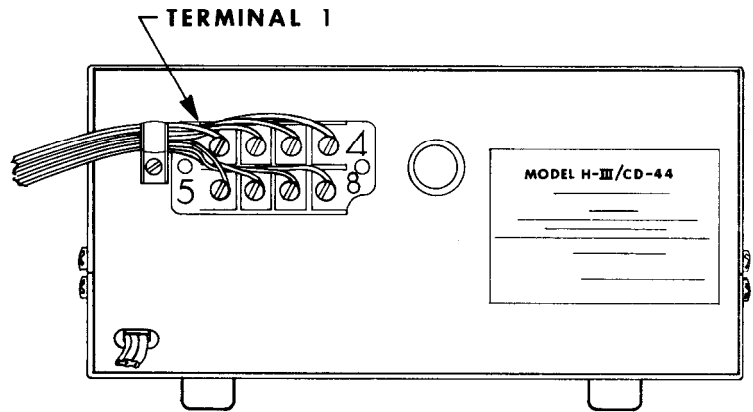

FIG. 5: CONTROL UNIT WIRING

5. If the tower selected has a top bushing that provides adequate clearance as the rotor is turned through 360°, observe that it will turn without restriction, the final installation of the rotator may be completed. If not, the rotator may have to be moved slightly on the flat plate and/or the mast may have to be shimmed using shims between the mast and the V-shaped bell rotator casting. If a high quality bearing is used in the top of the tower (RECOMMENDED) the shimming procedure must be done more carefully as closer tolerances are required. **IT IS IMPORTANT THAT THE ROTATOR NOT TRY TO TURN THE MAST ECCENTRICALLY WITH THE TOP BUSHING OR BEARING**
6. Tighten the four bolts carefully - to approximately 100 inch pounds of torque.
7. Insert the 1/4 - 20 x 1 1/4" bolt with a locking nut into the center tapped hole in the clamp plate. Tighten down to assure that the antenna mast does not turn in the upper mast support.
8. Re-attach the wires to the rotator in **EXACTLY** the same manner as used in the trial assembly and secure the wires to the tower in such a manner that the wires will not be strained.
9. Return the rotator to the full CCW "S" position. Mount the beam pointing South. The coaxial cable should be looped as per Figure 1 in such a manner that it will not foul or tangle when the beam turns around in a circle to the full 360° clockwise position.

B. OUTSIDE TOWER

Referring to figures 2, 3 and 7 an outside tower or pole mount is made in the same manner except that the rotator is fastened by four bolts to the lower mast support, P/N 51467-10. Since the eccentricity of the rotator turning in reference to the tower is no longer important, the shimming procedure is not necessary. The four screws must be torqued to the same specification, and the 8-wire cable securely fastened. The lower mast should be pinned with the 5/16" - 18 x 4" bolt as shown in Figure 7. **CAUTION:** The rotator is designed for vertical operation with the bell shaped housing in the up position. Water and other contamination will get into the motor unit if it is mounted horizontally or up-side down.

VI. OPERATION

A. PRELIMINARY CHECK AND CALIBRATION

1. Turn the control box "on" with the upper right "on-off" switch. The meter should be lighted and the needle should be to the left.
2. If the meter is pinned to the right or shows approximately full scale, push in the "calibration" switch fully and release it. The needle now will be to the left. The calibration switch is a "push-on", "push-off" switch.
3. **METER CALIBRATION** of the extreme full scale (right hand or clockwise South) can be accomplished at any time without disturbing the rotator using the following procedure:
 - a. With the control unit "on", push in and release the "calibrate" knob.
 - b. The meter should now indicate full scale to the right. If it does not, turn the calibrate knob until it does.

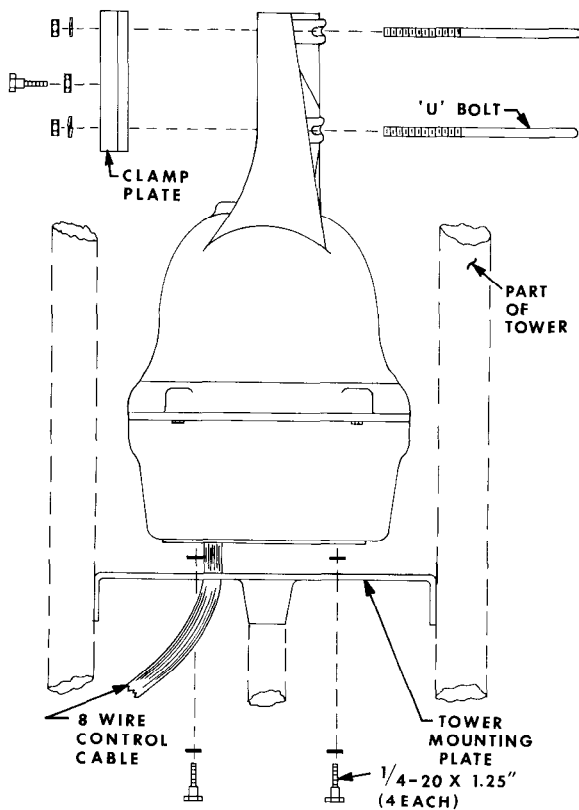

FIG. 6
ROTATOR MOUNTING
IN A TOWER

- c. Without turning the knob, push it in and release it. The right scale is now fully calibrated to adjust for minor variations in component values. Do not, then, turn the knob, even in the "push-off" position because to do so will require that it again be recalibrated.

It is not normally necessary to adjust the left hand position of the needle.

If it becomes necessary to adjust the left hand needle position, use the following procedure:

1. Turn the control "on" depress the brake lever and turn the rotor using the left rotation lever to full end of rotation until the needle stops moving, release the two levers.
2. With the control unit turned "on" carefully adjust the zero left (CCW South) position with the screw directly under the meter to read exactly South. Unless the meter movement changes, it is not necessary to adjust its left position. Further "calibration" is to keep the full scale (right hand needle position) accurate.

When the control unit is turned "off", the meter needle will fall to the left "S" position and return to indicate the rotor position as soon as the control unit is turned "on" again. It will not damage the unit to leave it turned "on" for extended periods.

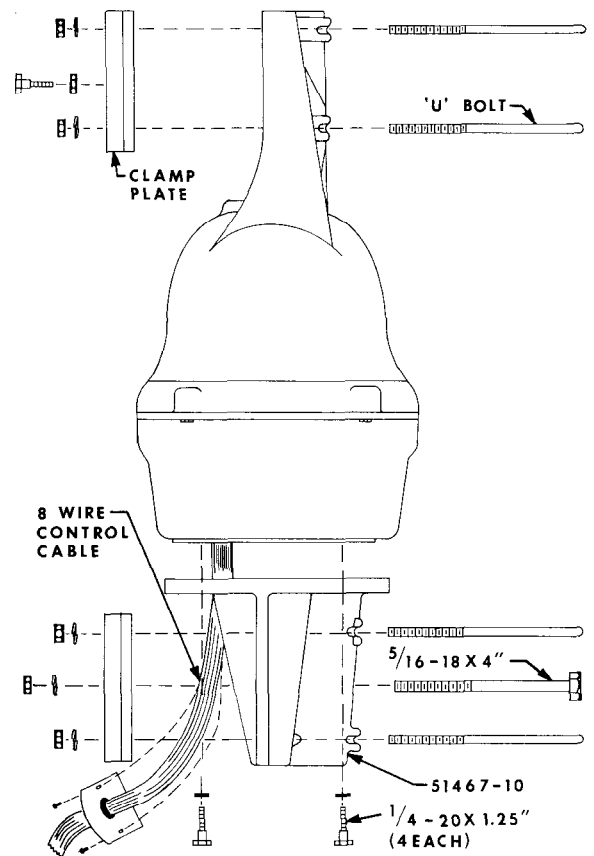

FIG. 7
ROTATOR MOUNTING WITH
LOWER MAST SUPPORT

B. NORMAL OPERATION

To operate the rotor, it is necessary to understand the **HAM III BRAKE RELEASE LEVER** and its function. The brake lever (middle lever) on the **CONTROL UNIT** operates a brake wedge mechanism in the rotator which locks the rotator into position mechanically. The rotator cannot turn unless the wedge is retracted by depressing the middle lever. The normal operation is as follows.

1. Retract the brake wedge by holding down the "Brake Release", middle lever.

2. Turn the rotor to the compass location by pushing down and releasing either the left hand lever or the right hand lever. **ALLOW A FEW SECONDS FOR THE ROTOR TO COAST DOWN.** Then re-engage the brake wedge by releasing the "Brake Release" (middle) lever.

C. OPERATING PRACTICE

The rotator has several mechanisms to protect it from misuse but the following **PRECAUTIONS ARE ADVISABLE:**

1. If you have a very large beam, the rotor can be "nudged" to exactly the desired position by alternately working the left and right control, allowing it to **COAST DOWN** before the brake wedge is allowed to engage.
2. It is advisable not to run it full speed into the end of rotation.
3. Upon completion of turning, always allow the rotor to coast down by keeping your finger on the "Brake Release" after you have released the rotation lever. This procedure will allow the rotator to stop **before** you re-engage the brake wedge. Observing this sequence prevents the rotator from stopping suddenly thus preventing undue stress on the rotator, beam, and tower.

The motor has an internal brake which controls the coast down time and deceleration. The internal motor brake is usually strong enough to prevent pinwheeling during operation even in high winds. If the rotator is being operated in a very high wind, observe the operation of the needle. A little practice will acquaint the owner how to operate the rotor smoothly.

VII. GROUNDING

The tower, or other metal support device must be grounded to earth ground **at location.** Use heavy copper cable looped so that if the tower comes down for any reason there will be adequate slack to prevent the ground wire from breaking. Use one or more 18" copper jacketed steel stakes driven into the moist earth and fasten the wire securely at the stake and at the tower.

As mentioned in the "Cautions" portion, the steel chassis of the control box should be either grounded to a metal cold water pipe in the house or back to the electric service entrance box where the power comes into the house. This normally is accomplished with the wire of the 3 prong plug which then depends on the 120 volt wall outlet being adequately grounded back to the service entrance as well as to the utility ground. If there is any doubt, have this checked by a licensed electrician.

CONSTRUCTION and SERVICING

I CONTROL UNIT - GENERAL DESCRIPTION

See Page 12 and 13

1. **POWER:** The on/off switch is a turn-to-operate type. The unit is protected by a 3 amp line fuse which is located in a fuse holder on the back panel. The power transformer supplies power for the rotator motor. The transformer is protected by a thermal cut-out switch located in the primary. If the cut-out switch opens, turn the unit off and wait 10-15 minutes before resuming operation.
2. **METER CIRCUIT:** The position indicator meter and its circuitry is powered by the meter transformer. When the power switch is "on" the meter is illuminated and continually indicates rotator position. Stability is assured by the 13 volt

VIII. OPTIONAL ACCESSORY KITS

50924 - 10 South Center Meter Scale Kit \$3.00

The stock Ham-III/CD - 44 control is produced with North Centered meter scale. Since some locations and/or popular working areas may favor rotation stops at North, we provide a South Centered meter scale kit for field modification.

50559 - 10 Tower Mounting Plate Kit \$4.50

The tower mounting plate kit is a flat plate equipped with four 0.5 inch standard bushings drilled to match the hold down screw holes in the bottom of a CDE Bell type rotator. The plate essentially is designed to allow enough clearance under the bottom of the rotator to permit the rotator to turn without touching the 8-wire control cable.

On any inside tower installation, care must be exercised to get the top mast shimmed to the exact rotational center of the rotator upper mast support. The geometry is such that a mast of 52 mm (2.062 inches) will be exactly centered. For each 1.6 mm (.0625 inches) less mast diameter used, .8 mm (.031 inches) of shim must be wrapped around the mast at the clamping points.

51467 - 10 Heavy Duty Lower Mast Support Kit \$29.95

The stock HAM III is intended to mount on the base plate inside of the tower. However, in some instances outside tower or mast mounting is desired as per figures 2 and 3. This kit, part number 51467-10, contains a heavy duty lower mast support and the necessary hardware to facilitate mounting the HAM III on top of a tower stub or mast. Caution, when the rotator is installed using the lower mast support kit, the antenna size must be restricted to 7.5 square feet of wind surface area.

zener regulated power supply. Circuit is protected by the 1/8 amp fuse.

3. **CALIBRATION:** The calibration switch is a push-on/push-off, turn to adjust type. It calibrates the right hand position (full scale) of the meter.
4. **ROTATOR CONTROL:** CCW rotation is controlled by the left hand lever and CW rotation by the right hand lever. The center lever is the brake release.

II ROTATOR - GENERAL DESCRIPTION

See Pages 14 and 15

1. **OUTER HOUSING:** The upper mast support (Bell) and the the brake housing are cast aluminum. The upper mast support is secured to the brake housing by four 12-24 x 3/4" self tapping hex head screws.

2. **POSITION SENSOR:** The position sensing potentiometer is located in the top of the bell casting.
3. **DRIVE:** A low voltage AC motor and its associated gears drive the output ring gear at about 1 RPM. The ring gear return is mechanically interlocked to the upper mast support (Bell).
4. **BRAKE:** The brake wedge and its associated components are enclosed by the lower housing casting. Seventy-five grooves are cast into the inside surface of the brake casting walls which are engaged by the brake wedge. The wedge is retracted by a solenoid which is controlled by the "Brake Release" (Center) switch on the Control Unit.
5. **ROTATION LIMITS:** Two electrical, end of rotation switches, activated by the stop arm, disconnect the motor power just before the rotating bell housing reaches its full CCW (0°) or CW (360°) positions.
6. **BEARINGS:** Two rows of ball bearings are provided. Lubricate sparingly with factory approved special low temperature grease (P/N 51497-10).

III TROUBLE SHOOTING

A. GENERAL

Most operational difficulties with rotors are traceable to broken, shorted, or grounded wires usually at the terminal strips. Time spent in cutting the leads to exact lengths, timing, forming, and wrapping around terminals, cutting insulation to exact length, and clamping to prevent strain on any single wire, will pay dividends.

B. MECHANICAL PLAY

Frequently the slight motion of the antenna array in gusts of wind is due more to the natural flexing of the elements and most than it is due to actual play in the rotator mechanism. A slight amount of "play" is built into the rotator to avoid binding due to environmental changes.

C. ANTENNA ROTATES IN HEAVY WIND

This is usually a matter of the mast slipping in the support. If "slipping" or "turning" is suspected return the rotator to the end of rotation and visually check to be sure that the antenna is in the original stop location as installed. Check the nuts on the U bolts to insure that they are tight. Also check that the center bolt in the mast clamp is tight.

D. LACK OF POWER

If the antenna rotation is slow or sluggish or hard to start, check for proper voltages. If the voltages are correct, the 120-140 MFD motor start capacitor could be at fault. It is recommended that a new capacitor be tried before any other action is taken. If the electrical circuit is OK, then check for mechanical binding. Pay particular attention to bearings and alignment of the shaft on an inside tower mount. On any inside tower installation, care must be exercised to get the top mast shimmed to the exact rotational center of the rotator upper mast support.

E. IMPROPER METER INDICATION

The brake and motor operate independently of the indicating system. If the pilot light burns at proper brilliancy the instrument transformer is OK and the output is not shorted. Check the 1/4 AMP

meter circuit fuse with an ohmmeter. Check for about 13 VDC across terminals No. 3 and No. 7 with the switch operated. If the proper voltage is not obtained, check the individual components in the meter circuit. If the 13 VDC is present, check for 500 ohms across rotor leads No. 3 and No. 7. If 500 ohms is present from No. 3 and No. 7, see if the readings from No. 3 to ground and No. 7 to ground total 500 ohms.

NOTE: If the needle remains in the right hand "S" position check to be sure the calibration switch is not in the "calibrate" position.

An intermittent condition in any component in the rectifier or meter circuits within the control box, as well as in the cable or potentiometer circuit in the rotator itself can cause meter fluctuation or error. Possible cause of such trouble may be localized by placing a test DC meter across terminals No. 1 and No. 3 or No. 1 and No. 7 comparing the action of the test meter with the panel meter.

F. NO ROTATION - INDICATION OK

Either the thermal cutout in the power transformer has opened or there is actually trouble in the motor circuit. After allowing time for the thermal cutout to restore service, proceed to "checking rotator from ground" and "checking control unit".

G. GROUND WIRES

Grounds on cable leads can burn out either the line fuse or the small fuse in the meter circuit. If lead No. 3 or lead No. 7 is grounded, it shorts out part of the potentiometer so that as rotation progresses to the other end, the full DC voltage is applied across a decreasing portion until current becomes so high that the potentiometer burns out. Note also that any grounds may put an overload on the power transformer which could cause the line fuse to blow, or overload the rectifier circuit so that the 1/8 amp fuse blows.

H. CHECKING THE CONTROL UNIT

1. VOLTAGES WITH UNIT PLUGGED IN.

To check the control unit, plug the line cord into 120 volt AC power. With no connections to the terminals turn the on-off switch to the "on" position, the meter light will illuminate. The meter needle will remain on the left hand "S". Terminals 1 and 2 should show 30 volts AC (approximately) when the brake lever is depressed.

Terminals 1 and 5 should show 30 volts AC with brake release lever depressed and CW lever depressed.

Terminals 1 and 6 should show 30 volts AC with brake release lever depressed and CCW lever depressed.

Terminals 3 - 7 should show approximately 13 VDC.

2. RESISTANCES WITH UNIT NOT PLUGGED IN

Disconnect the AC power source and remove the eight wire control cable. Be sure to tag each wire with the corresponding terminal number.

The control box can be checked without removing the cover by using a volt-ohmmeter to check values across terminals. Resistance across terminals No. 1 - 2 should read .4 Ohms. Read same value across terminals No. 1 - 5 with clockwise switch lever (right-hand) depressed and across terminals No. 1 - 6 with counterclockwise switch lever (left-hand) depressed. Resistance across input line cord with on-off switch in the "on" position and the brake lever depressed should read 3.8 Ohms.

I. CHECKING THE ROTATOR FROM THE GROUND

You may possibly avoid bringing the rotator down by making electrical checks from the control box position. This is done by disconnecting the 8 wires from the screw terminals and tagging them carefully No. 1 through No. 8 to correspond with the terminal numbers from which they were removed. From the schematic diagram it is apparent that the resistance of the lead wires will be added to the resistance of the motor windings and potentiometer strip in making the resistance checks as shown in Table 1

To Check	Read Resistance	Between TERMINALS
Brake Solenoid	.75 ohms + leads	1-2
½ Motor Winding	2.5 ohms + leads	1-8
½ Motor Winding	2.5 ohms + leads	1-4
½ Motor + Switch	2.5 ohms + leads	1-5
½ Motor + Switch	2.5 ohms + leads	1-6
Entire Motor	5 ohms + leads	8-4
Right Limit Switch	0 ohms + leads	8-5
Left Limit Switch	0 ohms + leads	4-6
Entire Pot Switch	500 ohms	3-7
Pot Arm to + End	0 to 500 ohms	3-1
Pot Arm to — End	0 to 500 ohms	1-7

Table 1

IV. DISASSEMBLY OF THE ROTATOR

In order to service the rotator, the unit must be disassembled. We recommend the following procedure:

1. Set the rotator on a flat surface.
2. Remove four screws and carefully raise top casting to expose potentiometer and drive mechanism.
3. Carefully remove upper ball retaining ring. Keep it circular, and lay it on clean paper.
4. See that the potentiometer strip is clean and not burned at either end and that the arm is clean at the point of contact. Use only fine rouge cloth to polish the contact arm.
5. If the drive ring happens to be near the end of rotation, hold the unit horizontal, operate the spur gear to rotate the mechanical stop on the drive ring away from the area of the limit switch. See that the mechanical stop lever (which is positioned between the two limit switches) will open each electrical contact before it hits the corresponding mechanical stop. Also see that the stop lever has not been deformed and that the electrical contacts are clean and uncorroded. Rotate the top spur gear several revolutions to determine that the motor and its bearings are operating freely. Look for broken teeth in any of the gears.
6. Lift the motor and brake mechanism out of the brake housing. Carefully remove the lower ball bearing retainer and place it on a clean piece of white paper.
7. Remove the ring gear from the motor base. This is accomplished by first pulling up on the side opposite the gear train. Then raise the entire ring slightly upward with the side away from the gear train so that it will slide out from under the gears. Examine closely for evidence of broken or worn teeth.
8. Examine the inside of the screw terminal strip to see that there is proper clearance between the solder lugs and frame and that there are no breaks in the insulation. Pay particular attention to the insulation at the point where the wires are held in the metal clip.

9. Examine the teeth in the brake casting.
10. To separate the motor, pot, and gear assembly from the brake assembly, unsolder the solenoid leads from the terminals 1 and 2. Remove the screws holding the terminal board to the casting. Then remove the four large screws in the base. Be careful to clear the wires and the terminal strip through the opening.
11. To remove the potentiometer, remove the hex nuts and unsolder the leads. The mounting studs are integral to the motor and bell. In replacing the pot be sure the connections are on the side which overhangs the motor.
12. To replace the motor, first remove the pot per Paragraph 11, then unsolder the black motor lead from the screw terminal 1, the red lead from the inside left limit switch lug, and the blue lead from inside the right switch lug. The fastenings holding the motor on the studs may then be removed and the motor pulled up and out. In replacing a motor, be sure to see that the round hole in the motor is next to the limit switch. Use a double lock nut on this stud near the limit switch, to provide clearance for the leads. Use special internal-external lockwasher over the stud that works in the slotted hole in the motor. Be sure that the pinion is snug against the spur gear before tightening this fastener over the slot.
13. When it is necessary to closely inspect or replace gears, it is possible to remove the motor, limit switch, pot, and terminal strip without unsoldering more than the solenoid leads from terminals 1 and 2. Remove the motor fastenings from the mounting studs. Work the motor up and out, exercising care in pulling the leads and terminal strip through the window in the gear housing. Remove the plate to expose the gears. Carefully note the positions for proper replacement.

V. RE - ASSEMBLY OF THE ROTATOR

It is assumed in the following instructions that the brake mechanism is assembled and operative. The motor and gear train along with the potentiometer and the limit switches are likewise assembled and wired and operative.

It is not likely that the brake wedge will be exactly positioned in relation to the teeth in the brake housing to permit proper assembly unless the brake mechanism is retracted. For this reason it is necessary to operate the brake mechanism electrically during step 8 of the assembly of the rotator unit.

1. See that a small amount of low temperature, high quality light weight grease is conservatively distributed around the ball bearings, ring gear, and spur gears. Only an even film of grease is desirable (approximately one thimbleful of grease should be used to lubricate a completely dry rotator). Excessive grease will only run out in high temperatures or cause power loss in low temperatures.
2. Rotate the upper spur gear until the inwardly protruding mechanical stop on the ring gear engages the channel shaped stop lever and pushes it far enough to the right to just open the right hand limit switch contact (it is assumed that the rotator is viewed from the side of the limit switch). This situation represents the extreme counterclockwise end of rotation. The potentiometer arm must then be rotated to its extreme counterclockwise position against the top stop.
3. Secure the upper bell housing upside down by the mast support in a vise with the open end of the "V" toward the bench. The boss which drives the potentiometer arm which is located in the bottom part of the bell housing will then be to the left of center.

4. Clean the inner portion of the housing and apply a small amount of grease to the ball race. Then carefully insert one ball bearing assembly with the flanged rim up and against the outer edge of the casting.
5. Grasp the operating mechanism by the flat base, steady the ring gear, invert the mechanism and lower it into the housing. In doing this, note that the serrated portion of the potentiometer arm must engage the driving boss in the housing and that the three driving bosses on the ring gear must engage into the mating recesses in the top housing. This situation will result automatically if the previous instructions have been followed.
6. Clean the exposed bearing race and apply a film of grease. Then apply the top bearing assembly to the race with the rim downward.
7. Clean the brake housing. Lower the brake housing into place so that the assembly holes will approximately line up with the threaded holes in the bell housing. **DO NOT MECHANICALLY FORCE AN EXACT ALIGNMENT OF THESE HOLES WITHOUT ELECTRICALLY RETRACTING THE BRAKE MECHANISM.**
8. Connect the control unit terminals No. 1 and No. 2 only to the corresponding terminals on the rotator while it remains clamped in the vise. Momentarily operate the "Brake Release". This will permit the brake housing to freely rotate for exact alignment of the holes. With the brake retracted, secure the upper mast support (bell) to the lower brake housing. Tighten finger tight. With the brake retracted, tighten all 4 bolts in an alternate pattern to approximately 85 inch pounds, of torque. Recheck the brake to make sure that it operates freely.
It is suggested that all 8 wires be connected from the control box while the rotor is still on the bench and that its complete operation be checked.

LIMITED WARRANTY
<p>CORNELL-DUBILIER ELECTRIC CORPORATION (CDE) warrants that your new ROTOR has been manufactured free of defects in design, material and workmanship. If this product fails to give satisfactory service due to defects covered by warranty, including any warranty implied by law such as WARRANTIES OF MERCHANTABILITY OR FITNESS, for a period of ONE YEAR FROM THE DATE OF PURCHASE, CDE will, at its option, replace or repair the unit, or any defective part free of charge.</p> <p>To obtain warranty service, return the ROTOR to your dealer, or pack it securely, and send it with proof of purchase date and a letter explaining the problem, shipping cost prepaid, to: CORNELL-DUBILIER ELECTRIC CORPORATION, WARRANTY REPAIR DEPARTMENT, 118 E. JONES ST., FUQUAY-VARINA, N.C. 27526.</p> <p style="text-align: center;">IMPORTANT</p> <p>Warranty service covers repair or replacement of the ROTOR only. CDE is not responsible for costs of removal or reinstallation, or shipping to the place of repair. The warranty period is not extended due to repair or replacement. CDE reserves the right to make reasonable charges for service if there is evidence of damage due to alteration, misuse or installation not according to the enclosed instructions.</p> <p>CDE IS NOT RESPONSIBLE FOR DAMAGE TO OTHER EQUIPMENT OR PROPERTY OR FOR ANY OTHER CONSEQUENTIAL OR INCIDENTAL DAMAGES OF ANY KIND, WHETHER BASED ON CONTRACT, NEGLIGENCE OR STRICT LIABILITY. MAXIMUM LIABILITY SHALL NOT, IN ANY CASE, EXCEED THE PURCHASE PRICE OF THE UNIT.</p> <p>(Some states do not allow limitations on how long an implied warranty lasts, or the exclusion or limitation of incidental or consequential damages, so the above limitations and exclusion may not apply to you.)</p> <p>(This warranty gives you specific legal rights. You may also have other rights which may vary from state to state.)</p>

VI. HOW TO GET FACTORY SERVICE

If service is required, the unit must be packed securely and sent prepaid to:

CORNELL-DUBILIER ELECTRONICS
 Rotor Service Department
 118 East Jones Street
 Fuquay-Varina, N. C. 27526
 919-552-2281

For units that are in warranty, no charge will be made for any repair work required. Include a copy of your sales receipt. For out-of-warranty units, the following flat rate charges apply:

Control Unit Only	\$23.00
Rotator Only	25.00
Complete Unit - Rotator and Control	36.00

The above flat rate charge includes rebuilding the unit, replacing all defective and/or worn parts, and return freight charges. CDE reserves the right to change prices at its option. When returning items for repair, a check or money order for the repair charges must be included. Be sure to include your name, address, zip code and telephone number. Also give a brief description of the problem.

IF YOUR UNIT IS DAMAGED, CONTACT YOUR DEALER OR THE SHIPPER. IF ANY OF THE ITEMS ARE MISSING, RETURN THE COMPLETE UNIT TO YOUR DEALER OR WRITE THE FACTORY FOR ASSISTANCE. A COPY OF YOUR SALES RECEIPT MUST ACCOMPANY ANY RETURN.

HAM III SPECIFICATIONS

- **Input Voltage:** 120 VAC 50 - 60 Hz
 Optional: 220 VAC 50 - 60 Hz
- **Motor:** 24 VAC, 2.25 Amp, Capacitor Start, Capacitor Run
- **Power Transformer:** 120 VAC/26 VAC 10% duty, thermal switch protected
 Optional: 220 VAC/26 VAC 10% duty, thermal switch protected
- **Meter Transformer:** 120 VAC/23 VAC Continuous duty
 Optional: 220 VAC/23 VAC Continuous duty
- **Meter** DC voltmeter 1000 ohms/volts, 1 MA full scale
- **Meter Scale:** Direct reading: North centered, 5° increments
 Optional: South centered, 5° increments.
- **Recommended 8 - wire interconnect cable:** Stranded Copper

<u>Maximum Length</u>	<u>Gauge for Terminals 1 & 2</u>	<u>Gauge for Terminals 3 - 8</u>
125' (38M)	#18 (1.19mm)	#22 (.76mm)
200' (61M)	#16 (1.42mm)	#20 (.97mm)
300' (91M)	#14 (1.75mm)	#18 (1.19mm)
500' (152M)	#12 (2.32mm)	#16 (1.42mm)
800' (244M)	#10 (2.95mm)	#14 (1.75mm)

- **Maximum Antenna Size**
 - A. Tower Mounted as per Figure 1 - 12.5 square feet (1.16M²) of wind surface area.
 - B. Outside Tower or Mast Mounted as per Figure 2 or 3 - 7.5 square feet (.67 M²) of wind surface area.
- **Maximum Interconnect Cable Resistance:**
 - A. Terminals 1 and 2: .8 Ohm
 - B. Terminals 3, 4, 5, 6, 7 & 8: 2.0 Ohms
- **Rotation Time:** 45 - 60 seconds with 60 Hz input
- **Brake:** Positive, electrically operated wedge. 75 segments spaced 4.8° apart.
- **Rotator size:** 8 inches (20 cm) maximum diameter by 13.5 inches (34 cm) high.
- **Maximum antenna mast size:** 2 1/16" O. D. (52 mm).
- **Mounting hardware:** Stainless steel hardware and plated steel clamp plate.
- **Control unit size:** 8.125 inches (20.5 cm) wide x 8.25 inches (21 cm) deep x 4.125 inches (10.5 cm) high.
- **Shipping volume:** 2,280 cu. in. (37,350 ccms)
- **Shipping weight:** 23.4 pounds (10.6 kg)

PARTS AND PRICE LIST

CONTROL UNIT HAM III/CD-44 (SERIES 2)

PART NUMBER	DESCRIPTION	PRICE
51435-10	Control Unit, 120 VAC, Complete	\$104.95
51436-10	Printed Circuit BD. Assy., Complete	15.00
	C-1 Capacitor 470 MFD 50V (1)	
	R-1 Resistor 390 OHM 2W (1)	
	VR-1 Diode, Zener (1)	
	CR-1 Diode (1)	
	R-2 Resistor 10 K OHM ¼ W (1)	
	F-2 Fuse ⅛ AMP (1)	
51437-10	Expendable Parts Kit	3.00
	F-1 Fuse, ⅛ AMP (2)	
	F-2 Fuse, 3 AMP (2)	
	Bulb, Meter (2)	
51438-10	Switch Kit	4.80
	Switch, Micro, S-3, S-4, & S-5 (3)	
51439-10	Cover Kit	8.50
	Cover, Top (Black)	
	Cover, Bottom (Tan)	
	Screws (12)	
	Bumper Feet, Rubber (4)	
51440-10	Miscellaneous Hardware Kit	3.00
	Knob, On/OFF Switch (1)	
	Knob, Calibration Switch (1)	
	Bumper Feet, Rubber (4) and Screws (4)	
	Terminal Board Assy. (8 terminals) and Screws (2)	
	Lever, Switch (for S-3, S-4, & S-5) (3)	
	8 - Wire Cable Strain Relief & Screw	
51441-10	Transformer Kit (Power) 120 VAC	18.00
51442-10	Transformer Kit (Meter) 120 VAC	9.00
51172-10	Capacitor Kit Motor Start (C-2)	3.50
50861-10	Line Cord Kit, 3 wire	2.00
51443-10	Meter Kit ("N" Center)	24.00
	Bulb Holder (1)	
	Bezel (1)	
	Mounting Hardware	
51444-10	Switch Kit, On/Off (S-1)	2.00
51445-10	Switch Kit, Calibration (S-2)	5.60
51446-10	Fuse Holder Kit, F-2	1.90
51447-10	Face Plate Kit	3.10
51448-10	Chassis Kit	6.00

*Note: 115 VAC control unit can be converted to 220 VAC by installation of the 220 VAC power and meter transformers.

51449-10 Transformer Kit (Power) 220 VAC

51450-10 Transformer Kit (Meter) 220 VAC

To order parts, remit check or money order for total parts cost plus \$1.00 for postage and handling to: CORNELL-DUBILIER ELECTRONICS, Department "C", 118 E. Jones Street, Fuquay-Varina, North Carolina 27526.

PRICE SCHEDULE AS OF MARCH 1978

CDE reserves the right to change prices at its option. Current prices may be obtained by calling or writing the factory. Please send self addressed stamped envelope.

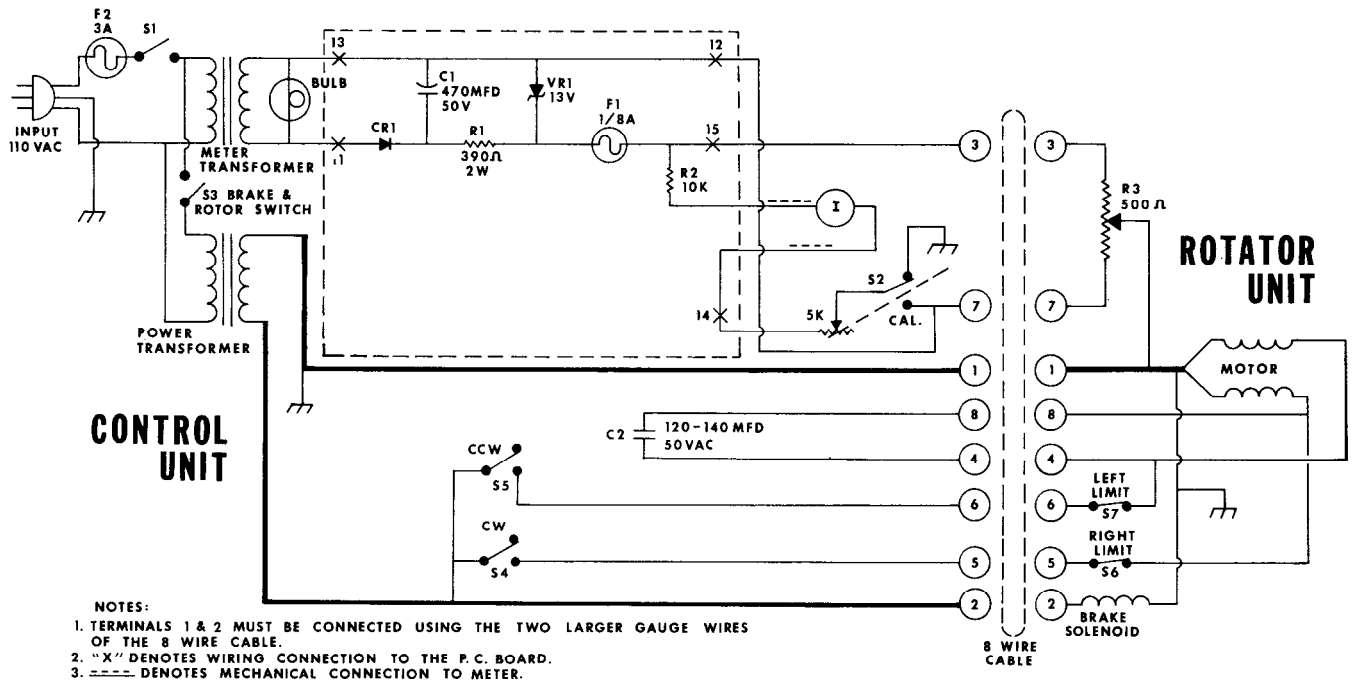

FIG. 8 SCHEMATIC

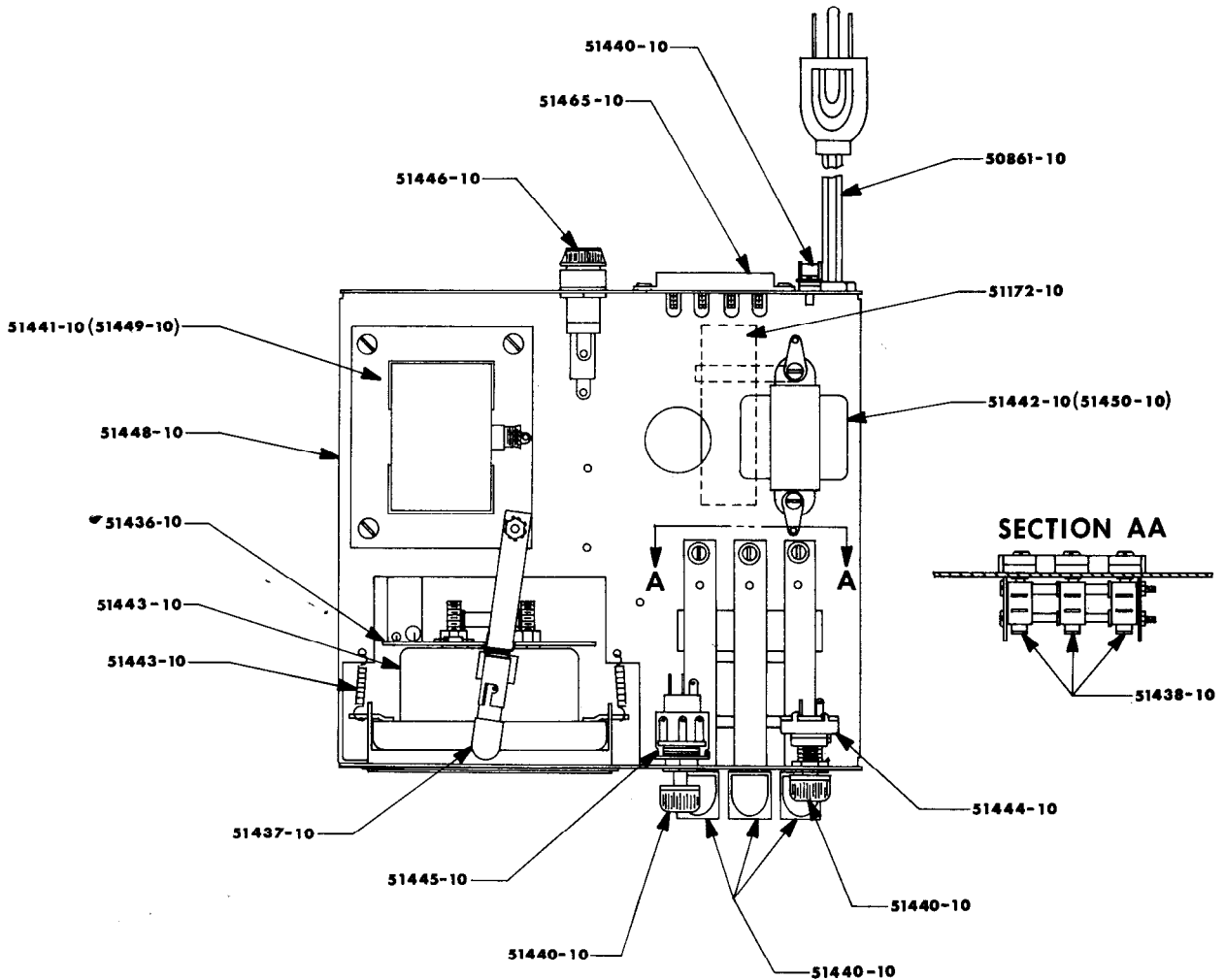

FIG. 9 CONTROL UNIT - TOP VIEW

PARTS AND PRICE LIST

HAM - III ROTATOR

PART NUMBER	DESCRIPTION	PRICE
51451-10	Rotator, Complete With Hardware	\$129.95
51452-10	Upper Mast Support Kit (Bell Casting)	10.00
51453-10	Brake Housing Kit (Lower Casting)	10.50
51454-10	Ball Bearing Kit (2-Required)	7.00
	Ball Bearings (49)	
	Bearing Retainer (1)	
51455-10	Brake Support Casting Kit	7.50
51456-10	Gear and Pinon Kit	10.00
	Gear & Pinion (1st, 2nd, & 3rd from motor) (3)	
	Gear & Pinion (Thick Pinion 4th from Motor) (1)	
	Small Gear Spacer (1)	
	Large Gear Spacer (1)	
	Washer (3)	
50313-10	Ring Gear Kit	3.50
51457-10	Final Spur Gear Kit	9.50
	Final Spur Gear (2)	
	Bushing For Spur Gear (1)	
50423-10	Stop Arm Kit	2.00
50370-10	Base Casting and Gear Shaft Assembly Kit	6.00
51459-10	Motor Mounting Plate Kit	5.00
51470-10	Motor and Pinion (Brass) Kit	25.00
51461-10	End of Rotation Switch Assembly Kit	3.50
	Switches (2)	
	Bracket (1)	
51460-10	Potentiometer Kit (R-3)	9.60
51462-10	Solenoid (Brake) Kit	10.00
51463-10	Solenoid Hardware Kit	3.00
	Solenoid Pin (1)	
	Solenoid Pin Spacer (3)	
	Solenoid Retaining Ring (2)	
	Solenoid Retaining Springs (2)	
	Retracting Spring Clip (2)	
51464-10	Brake Wedge Kit	12.00
	Brake Wedge (1)	
	Connecting Links (2)	
	Connecting Link Pin (1)	
	Brake Wedge Support (1)	
	Brake Latch (1)	
	Latch Pin (2)	
	Latch Pin Retainer (2)	
	Latch Spring (2)	
51465-10	Terminal Board Assy (8 terminals) Kit	2.00
	Terminal Board (1)	
	Screws (2)	
51466-10	Hex Head Screw Kit	1.00
	Screw, 12-24 x 3/4 (Taptight) (4)	
51415-10	Mounting Hardware Kit	7.00
	50115-00 Mast Clamp (1)	
	50382-00 "U" Type Bolt (Stn. Stl.) (2)	
	50502-00 Spacer (4)	
	Screw, Hex Hd. 1/4-20 x 1 1/4 (5)	
	Hex Nut 1/4-20 (Stn. Stl.) (5)	
	Lockwasher, Split 1/4" (9)	
51497-10	Grease, Special Kit	1.00
	(Quantity for one overhaul)	

To order parts, remit check or money order for total parts cost plus \$1.00 for postage and handling to: CORNELL-DUBILIER ELECTRONICS, Department "C", 118 E. Jones Street, Fuquay-Varina, North Carolina 27526.

PRICE SCHEDULE AS OF MARCH 1978

CDE reserves the right to change prices at its option. Current prices may be obtained by calling or writing the factory. Please send self addressed stamped envelope.

HAM - III ROTATOR

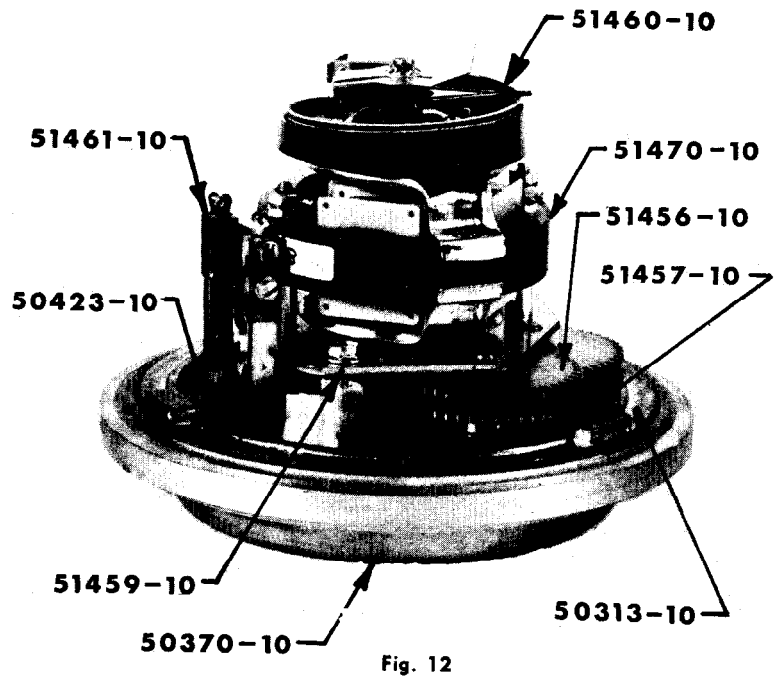
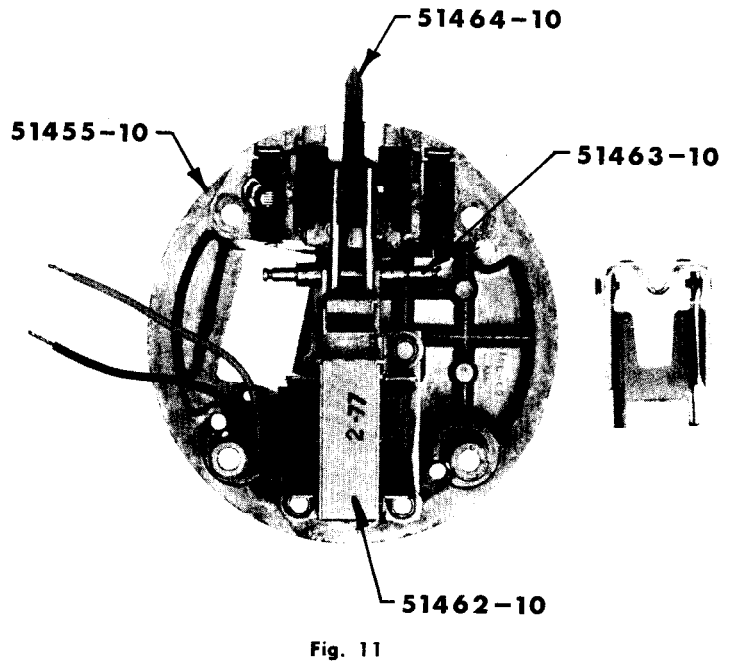
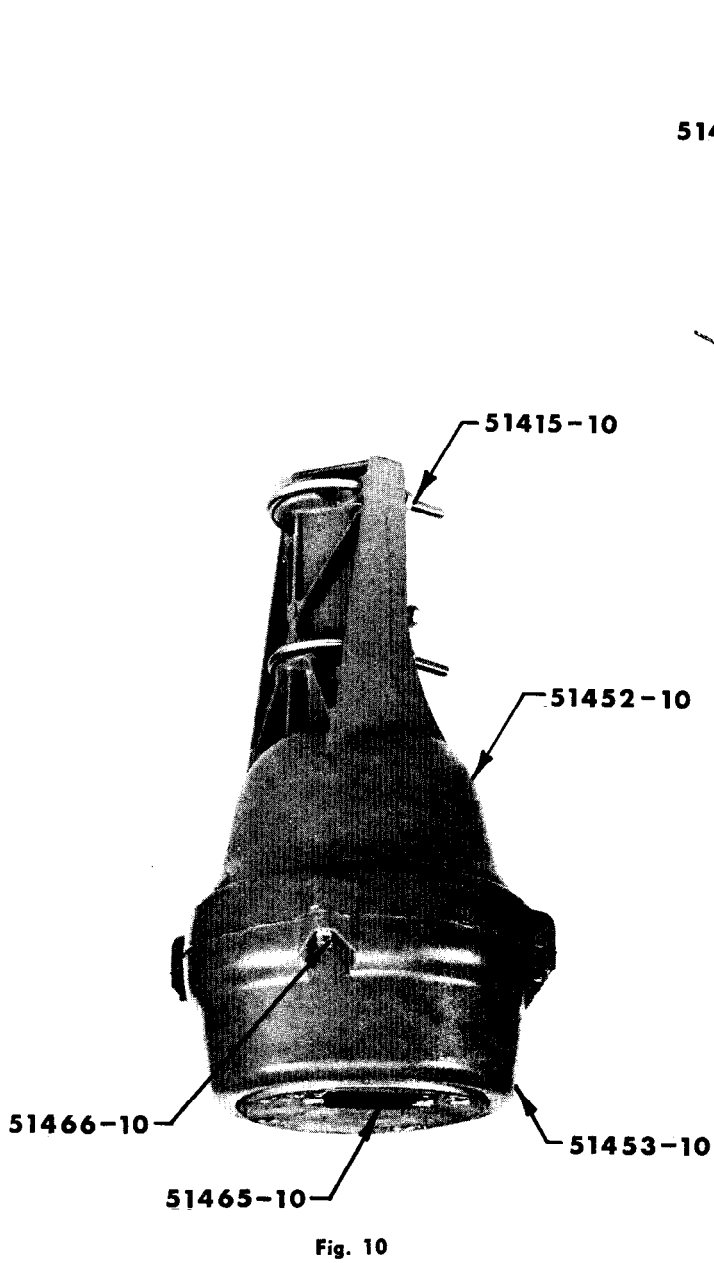

CLEARANCE HOLES TO BE 17/64

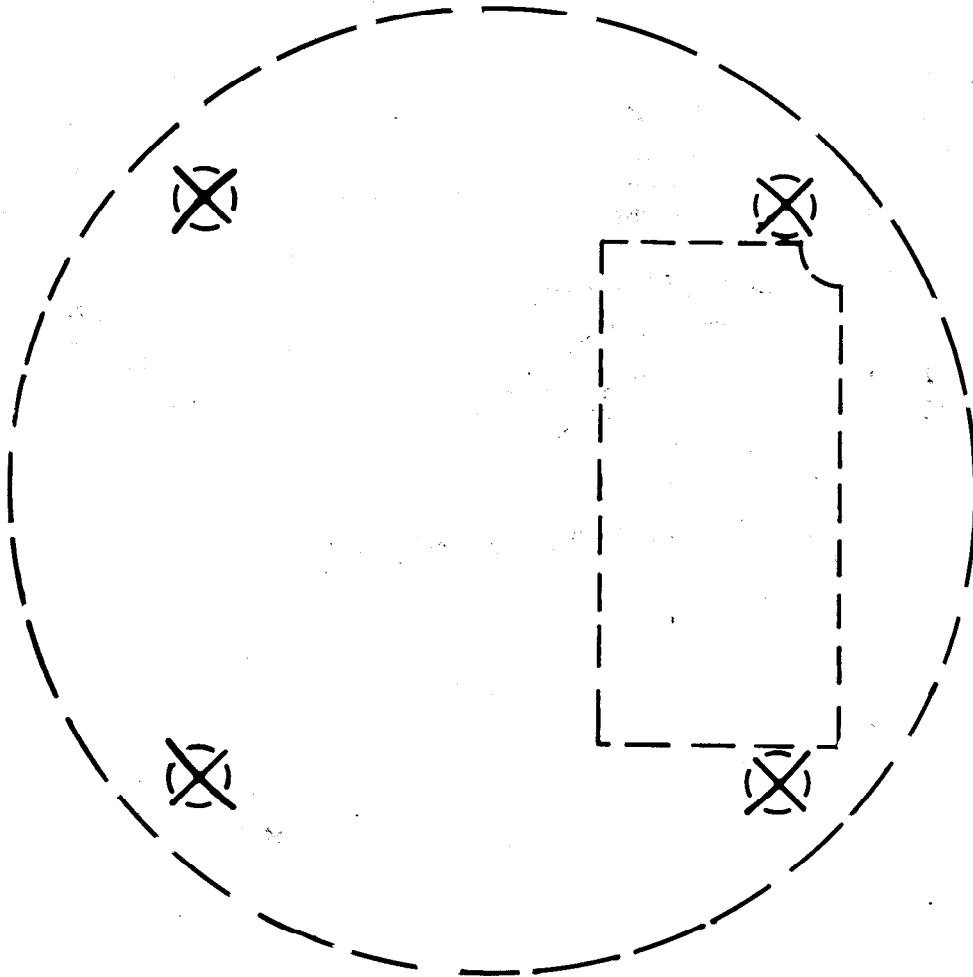

TOWER DRILLING TEMPLATE

This information is believed correct, but no warranty is given or implied and no liability is assumed by CORNELL-DUBILIER as to its accuracy or completeness. Changes may be made from time to time so that the user should verify all factors that may be critical. This information is not to be construed as authorizing or advising use of any patented invention.